

## Tuesday 14 June 2022 – Morning

### Level 3 Cambridge Technical in Engineering

**05823/05824/05825/05873** Unit 23: Applied mathematics for engineering

Time allowed: 2 hours

**C305/2206**



**You must have:**

- the Formula Booklet for Level 3 Cambridge Technical in Engineering (inside this document)
- a ruler (cm/mm)
- a scientific calculator



Please write clearly in black ink.

Centre number

--	--	--	--	--

Candidate number

--	--	--	--

First name(s)

---

Last name

---

Date of birth

D	D	M	M	Y	Y	Y	Y
---	---	---	---	---	---	---	---

### INSTRUCTIONS

- Use black ink. You can use an HB pencil, but only for graphs and diagrams.
- Write your answer to each question in the space provided. If you need extra space use the lined pages at the end of this booklet. The question numbers must be clearly shown.
- Answer **all** the questions.
- Where appropriate, your answer should be supported with working. Marks might be given for using a correct method, even if your answer is wrong.
- Give your final answers to a degree of accuracy that is appropriate to the context.
- The acceleration due to gravity is denoted by  $g \text{ m s}^{-2}$ . When a numerical value is needed use  $g = 9.8$  unless a different value is specified in the question.

### INFORMATION

- The total mark for this paper is **80**.
- The marks for each question are shown in brackets [ ].
- This document has **20** pages.

### ADVICE

- Read each question carefully before you start your answer.

FOR EXAMINER USE ONLY	
Question No	Mark
1	/12
2	/12
3	/12
4	/9
5	/13
6	/10
7	/12
<b>Total</b>	<b>/80</b>

Answer **all** the questions.

1

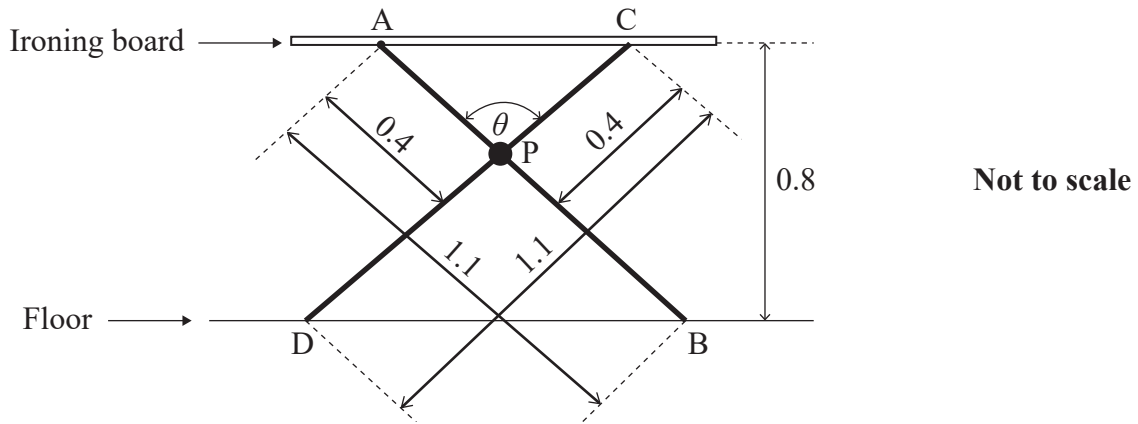

**Fig. 1**

**Fig. 1** shows a side view of an ironing board supported in a horizontal position on two sloping legs AB and CD which each have a length of 1.1 m.

Leg AB is fixed on a hinge located on the underside of the board at point A while leg CD is locked into an anchor point at C, which is also located on the underside of the board.

The legs are connected together by a pivot at point P which is 0.4 m from both A and C.

(i) The flat surface of the ironing board is 0.8 m above the floor.

Calculate the angle between the two legs,  $\theta$ , shown in **Fig. 1**.

.....

.....

.....

..... [3]

(ii) Calculate the distance AC.

.....

.....

.....

.....

..... [3]



2 A small helicopter has mass 400 kg. The lift force,  $F$  N, provided by its rotor is modelled by  $F = 0.02N^2\rho$ , where  $N$  rpm is the rotational speed of the rotor and  $\rho$   $\text{kg m}^{-3}$  is the density of air.

In this question you should assume that the density of air at ground level is  $1.22 \text{ kg m}^{-3}$  and that this diminishes linearly by  $0.032 \text{ kg m}^{-3}$  for every 250 m of height above the ground.

(i) Calculate the maximum rotational speed of the rotor at which the free-standing helicopter will remain on the ground.

.....  
.....  
.....  
.....  
.....  
.....  
..... [2]

(ii) While the helicopter is on the ground, the pilot rapidly increases the rotational speed of the rotor to 450 rpm.

Calculate the initial vertical acceleration of the helicopter.

.....  
.....  
.....  
.....  
.....  
.....  
.....  
..... [3]

- (iii) On another occasion the helicopter is hovering at a height of 2500 m above the ground.

Calculate the rotational speed of the rotor.

.....  
.....  
.....  
.....  
.....  
.....  
.....  
.....  
.....  
..... [3]

- (iv) The maximum rotational speed of the rotor is 530 rpm.

Calculate the theoretical maximum height at which the helicopter is able to hover.

.....  
.....  
.....  
.....  
.....  
.....  
.....  
.....  
.....  
.....  
.....  
.....  
..... [4]

3

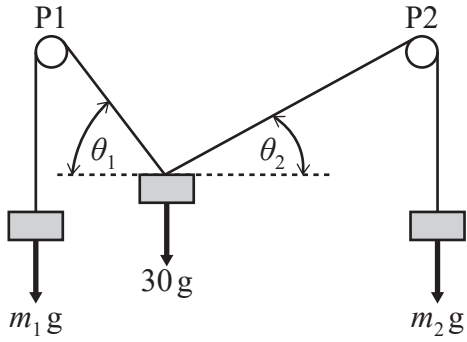

Fig. 3

A mass of 30 kg is supported in equilibrium by two light cables. The cables each pass over one of two fixed frictionless pulleys, P1 and P2, located above and on either side of the mass. Masses  $m_1$  kg and  $m_2$  kg hang vertically from the other ends of the two cables.

The end of the cable that passes over P1 is attached to the mass of  $m_1$  kg; this cable makes an angle of  $\theta_1$  with the horizontal. The other end of the cable that passes over P2 is attached to the mass of  $m_2$  kg; this cable makes an angle of  $\theta_2$  with the horizontal as shown in Fig. 3.

- (i) Form two simultaneous equations by resolving horizontally and vertically for the equilibrium of the mass of 30 kg. Each equation should contain  $m_1, m_2, \theta_1$  and  $\theta_2$ .

.....

.....

.....

.....

.....

.....

..... [3]

- (ii) Given that  $\theta_1 = 45^\circ$  and  $\theta_2 = 30^\circ$ , solve the equations to find the values of  $m_1$  and  $m_2$ .

.....

.....

.....

.....

.....

.....

.....

.....

..... [3]



- 4 (a) An electric current,  $I(t)$  Amps, varies with time,  $t$  hours.

This current delivers  $\int_0^T I(t)dt$  Amp-hours (Ah) in time  $T$  hours.

The current drawn at time  $t$  hours from a particular battery while being discharged is given by  $I(t) = 15e^{-t/10}$ , where  $t$  is the time in hours from the start of the discharge period.

Calculate the Amp-hours delivered by the battery during a 10-hour discharge period.

.....  
.....  
.....  
.....  
.....  
.....  
.....  
.....  
..... [4]

- (b) The capacity of lead-acid batteries used in road vehicles is rated in terms of Amp-hours (Ah). A fully charged battery rated at 80 Ah should deliver a constant current of 5 A for a discharge time of 16 hours. However, if the same battery is discharged with a higher current, for example 8 A, then the total discharge time will be less than 16 hours.

Peukert’s formula predicts the time, in hours, to completely discharge a fully charged battery with a constant current.

Peukert’s formula is often stated as follows.

$$t = H \left( \frac{C}{IH} \right)^k,$$

where  $t$  is the predicted discharge time in hours,

$C$  is the rated capacity in Amp-hours,

$H$  is the rated discharge time in hours,

$I$  is the constant discharge current in Amps,

$k$  is Peukert’s constant. This is a dimensionless parameter and typically has a value between 1.1 and 1.3.



- (i) Given that  $H = 16$ ,  $C = 80$  and  $k = 1.2$ , use Peukert’s formula to complete the following table.

Discharge current $I$ (Amps)	3	7
Predicted discharge time $t$ (hours)		

Use the space below for working if needed.

[2]

- (ii) Under experimental conditions a new battery is tested with the following parameters.

$H = 16$ ,  $C = 80$ ,  $I = 8$ ,  $t = 9$ .

Calculate the value of  $k$  in Peukert’s formula giving your answer correct to 2 decimal places.

.....  
.....  
.....  
.....  
.....  
.....  
.....  
.....  
.....  
.....  
.....  
.....  
.....

[3]



(iii) Sketch a graph of  $T$  against  $t$  on the grid below for  $t$  in the range 0 to 12.

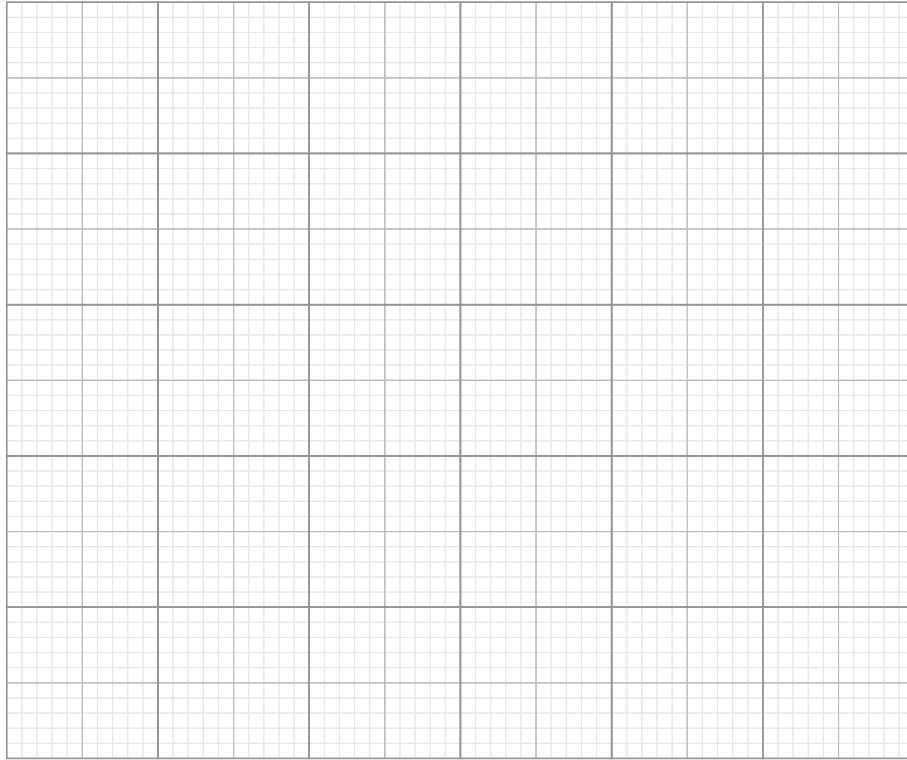

[3]

6 (i) Show that  $\sin^2 A = \frac{1}{2}(1 - \cos 2A)$ .

You may use trigonometric identities from section 1.4.1 of the Formula Booklet.

.....  
 .....  
 .....  
 .....  
 .....  
 .....  
 .....  
 .....  
 .....  
 .....  
 .....  
 .....  
 .....  
 ..... [3]

(ii) The electrical mains domestic supply in the UK is an alternating voltage given by  $v = V \sin(\omega t)$ , where  $V$  is peak voltage,  $\omega$  is frequency in radians per second and  $t$  is time in seconds.

The root mean square (RMS) value of this voltage is given by

$$\sqrt{\frac{1}{T} \int_0^T V^2 \sin^2(\omega t) dt}$$

where  $T$  seconds is the period of one complete voltage cycle.

(A) Show that  $T = \frac{1}{50}$  when  $\omega = 100\pi$ .

.....  
 .....  
 ..... [1]



7 Car ferry A leaves port P and travels at a constant speed along a straight path. Its position vector  $t$  hours after leaving P is  $5t\mathbf{i} + 20t\mathbf{j}$ .

Port Q is 10 miles due east of P. Car ferry B leaves Q at the same time as ferry A leaves P. Ferry B travels at a constant speed along a straight path. Its position vector  $t$  hours after leaving Q is  $(10 - 10t)\mathbf{i} + 15t\mathbf{j}$ .

In both cases the unit vectors  $\mathbf{i}$  and  $\mathbf{j}$  are associated with the directions east and north, respectively. Positions are distances measured in miles relative to P.

(i) Calculate the speed of ferry B.

.....

.....

.....

.....

..... [2]

(ii) Find the position vector of ferry B relative to ferry A.

.....

.....

.....

.....

..... [2]

(iii) Calculate the distance between the two ferries 1 hour after they leave the ports.

.....

.....

.....

.....

..... [2]



**ADDITIONAL ANSWER SPACE**

If additional answer space is required, you should use the following lined pages. The question numbers must be clearly shown – for example, 1(i) or 6(B).

A vertical line on the left side of the page is followed by 25 horizontal dotted lines, providing a ruled area for writing answers.



A series of horizontal dotted lines for writing, spanning the width of the page.

A series of horizontal dotted lines for writing, spanning the width of the page.

A series of horizontal dotted lines for writing, spanning the width of the page.



Oxford Cambridge and RSA

**Copyright Information**

OCR is committed to seeking permission to reproduce all third-party content that it uses in its assessment materials. OCR has attempted to identify and contact all copyright holders whose work is used in this paper. To avoid the issue of disclosure of answer-related information to candidates, all copyright acknowledgements are reproduced in the OCR Copyright Acknowledgements Booklet. This is produced for each series of examinations and is freely available to download from our public website ([www.ocr.org.uk](http://www.ocr.org.uk)) after the live examination series.

If OCR has unwittingly failed to correctly acknowledge or clear any third-party content in this assessment material OCR will be happy to correct its mistake at the earliest possible opportunity.

For queries or further information please contact the Copyright Team, OCR (Oxford Cambridge and RSA Examinations), The Triangle Building, Shaftesbury Road, Cambridge CB2 8EA.

OCR is part of Cambridge University Press & Assessment, which is itself a department of the University of Cambridge.

© OCR 2022

**C305/2206**