

Monday 23 May 2022 – Morning

Level 3 Cambridge Technical in Engineering

05822/05823/05824/05825/05873 Unit 2: Science for engineering

Time allowed: 1 hour 30 minutes

C302/2206



You must have:

- the Formula Booklet for Level 3 Cambridge Technical in Engineering (inside this document)
- a ruler (cm/mm)
- a protractor
- a scientific calculator



Please write clearly in black ink.

Centre number

--	--	--	--	--

Candidate number

--	--	--	--

First name(s)

Last name

Date of birth

D	D	M	M	Y	Y	Y	Y
---	---	---	---	---	---	---	---

INSTRUCTIONS

- Use black ink. You can use an HB pencil, but only for graphs and diagrams.
- Write your answer to each question in the space provided. If you need extra space use the lined pages at the end of this booklet. The question numbers must be clearly shown.
- Answer **all** the questions.
- Where appropriate, your answer should be supported with working. Marks might be given for using a correct method, even if your answer is wrong.
- Give your final answers to a degree of accuracy that is appropriate to the context.
- The acceleration due to gravity is denoted by $g \text{ m s}^{-2}$. When a numerical value is needed use $g = 9.8$ unless a different value is specified in the question.

INFORMATION

- The total mark for this paper is **60**.
- The marks for each question are shown in brackets [].
- This document has **20** pages.

ADVICE

- Read each question carefully before you start your answer.

FOR EXAMINER USE ONLY	
Question No	Mark
1	/7
2	/11
3	/13
4	/11
5	/9
6	/9
Total	/60

BLANK PAGE

PLEASE DO NOT WRITE ON THIS PAGE

Answer **all** the questions.

1 (a) State the SI base units for these quantities.

(i) mass

..... [1]

(ii) temperature

..... [1]

(iii) amount of substance

..... [1]

(b) An ammeter consistently reads 0.1 A more than the true current flowing through it.

(i) Circle the correct term to complete the sentence.

Readings from this ammeter are

absolute inaccurate imprecise relative

[1]

(ii) Which of these best describes the action that should be taken?

Tick **one** box.

Apply a -0.1 A absolute correction

Apply a $+0.1$ A absolute correction

Apply a -0.1 A relative correction

Apply a $+0.1$ A relative correction

[1]

(c) Define the term **uncertainty**.

.....

.....

..... [2]

- 2 Car wheels need to be balanced to prevent dangerous vibration from happening at certain speeds.

Fig. 1 shows a wheel-balancing machine. The engineer attaches the car wheel to the axle. The machine spins the wheel and the computer displays information.

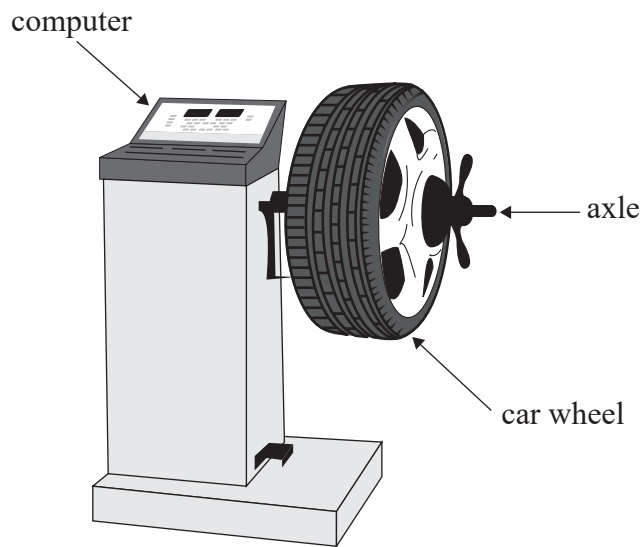

Fig. 1

- (a) (i) **Fig. 2** shows the wheel stationary on the machine's axle. The arrow labelled **W** represents the weight of the wheel. Draw an arrow **on Fig. 2** to show the force applied to the wheel by the axle.

[2]



Fig. 2

Fig. 3 shows the wheel on the axle, viewed from the side.

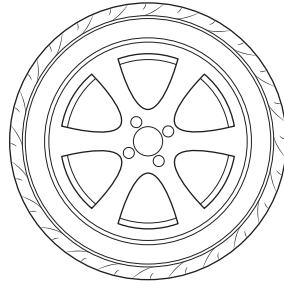

Fig. 3

When the engineer releases the wheel, it rotates clockwise.

(ii) Explain why this shows the wheel is **not** in equilibrium.

.....

.....

..... [2]

(iii) The engineer turns the wheel back to its original position and attaches a small weight to balance it.

Draw an X **on Fig. 3** to show approximately where the weight should be added.

[1]

(b) The owner of the car drives it away from the garage.

They drive the car at 10 m s^{-1} for 20 s and then stop for 10 s.

Show this journey on the distance–time axes below.

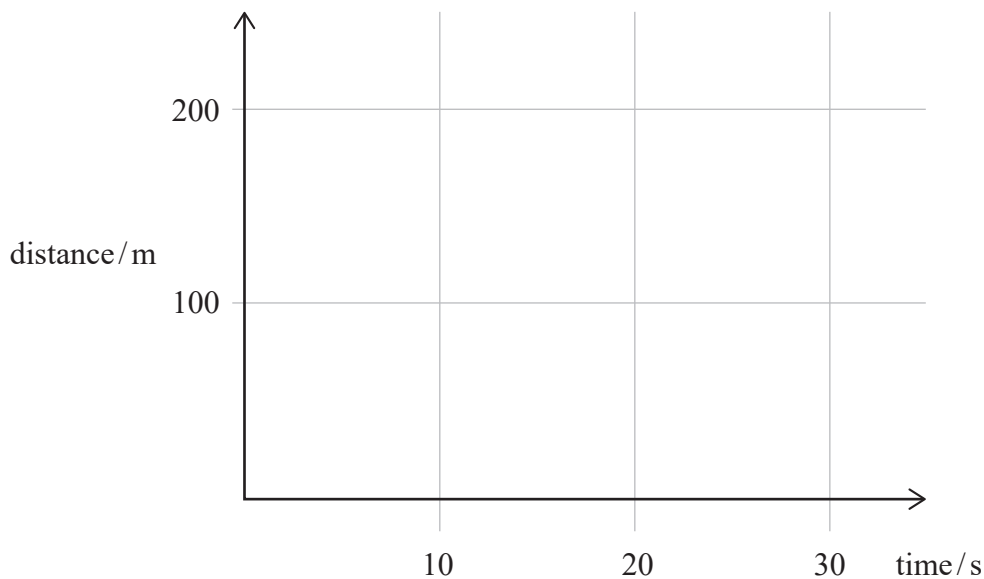

[3]

(c) The mass of the car is 500 kg.

Calculate the kinetic energy of the car when it is travelling at 10 m s^{-1} .

Give the units for your answer.

kinetic energy = unit [3]

3 (a) **Circle** the correct words to complete the sentence.

Conventional current flows from

negative to earth negative to positive positive to negative

[1]

(b) Explain how current flow in a semiconductor may differ from that in a metal.

.....
.....
.....
..... [2]

Question 3(c) begins on page 8

(c) Fig. 4 shows a semiconductor diode.

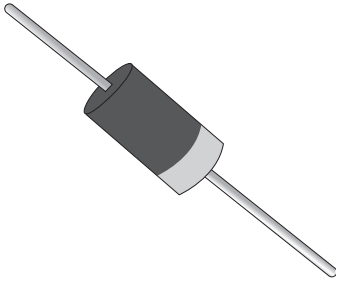

Fig. 4

The diode is connected in a circuit as shown in Fig. 5.

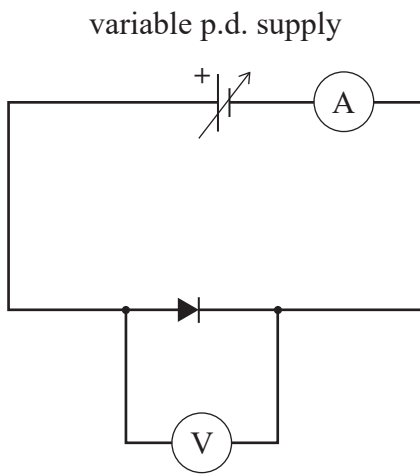

Fig. 5

The current through the diode is measured for different values of applied potential difference.

- (i) Calculate the resistance of the diode when the potential difference across it is 3.0 V and the current through it is 0.15 A.

Give the units for your answer.

resistance = unit [3]

(ii) The measurements are plotted on a graph.

Which of the following shows the current–potential difference characteristic for a semiconductor diode? Tick **one** box.

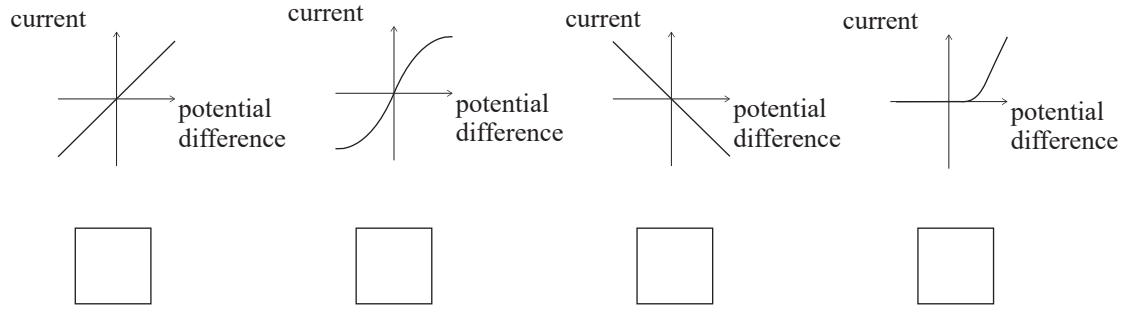

[1]

(d) Fig. 6 shows part of a circuit used to control a motor in a robot.

The motor acts like an inductor and the diode is connected in parallel with it to protect the rest of the circuit from voltage spikes.

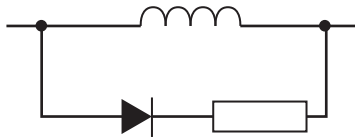

Fig. 6

The inductor coil is made up of 50 turns.

When the motor is running, the current is 150 mA and the magnetic flux is 1.2 m Wb.

(i) Calculate the self-inductance of the coil in milli-henry.

self-inductance = mH [4]

(ii) When the motor is turned off, the energy in the magnetic field is dissipated in the resistor.

Show that the power dissipated in the resistor is 3 W if the energy stored in the field is 0.075 J and the time taken is 25 ms.

[2]

4 (a) (i) Define **stress**.

.....
 [1]

(ii) State the unit for stress.

..... [1]

(b) Give an example of a brittle material.

..... [1]

(c) **Fig. 7** shows a force–extension graph for a brittle material, labelled **B**.



Fig. 7

(i) Draw, on the axes in **Fig. 7**, a force–extension graph for a ductile material.

Label this **D**.

[2]

(ii) Draw, on the axes in **Fig. 7**, a force–extension graph for a non-brittle polymer.

Label this **P**.

[2]

(d) A small force is applied to a brittle material.

The material does not break.

Describe what happens to the atoms in the brittle material when this force is removed.

.....
.....
..... [2]

(e) Explain the difference between elastic and plastic deformation of a material.

.....
.....
.....
..... [2]

Turn over for the next question

- 5 (a) Which of the following is **not** a fluid?

Tick **one** box.

Gas	<input type="checkbox"/>
Liquid	<input type="checkbox"/>
Solid	<input type="checkbox"/>

[1]

- (b) For safety, divers take a hollow plastic marker buoy to show their position.

- (i) Fig. 8 shows a diver holding their marker buoy underwater.

Fig. 9 is a close-up of the marker buoy.



Fig. 8

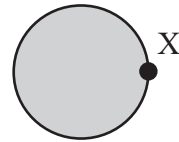

Fig. 9

The marker buoy in Fig. 9 is underwater.

Draw an arrow **on** Fig. 9 to show the direction that water pressure acts on the marker buoy at position X.

[2]

- (ii) The diver wears a device on their wrist that measures gauge pressure.

Which of the following is the correct way to convert the reading to absolute pressure?

Tick **one** box.

absolute pressure = atmospheric pressure – gauge pressure	<input type="checkbox"/>
absolute pressure = gauge pressure + atmospheric pressure	<input type="checkbox"/>
absolute pressure = gauge pressure – atmospheric pressure	<input type="checkbox"/>

[1]

- (iii) The top of the diver's marker buoy is 2.0 m from the surface.

Calculate the pressure on the top of the marker buoy due to the column of water above.

Density of seawater is 1020 kg m^{-3} .

pressure = Pa [2]

- (iv) **Circle** the correct words to complete the sentence.

The pressure on the bottom of the marker buoy is on the top.

less than

more than

the same as

[1]

- (c) Describe the upthrust force on an immersed object.

.....

 [2]

6 **Fig. 10** shows a type of household central heating boiler that includes a Stirling engine. This type of boiler heats water and also generates electricity.

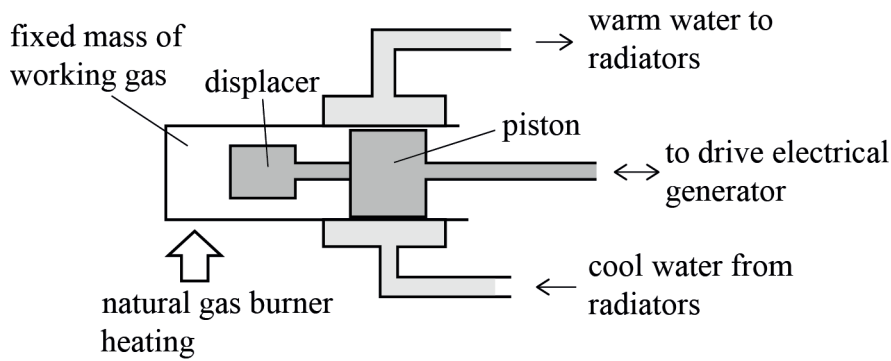

Fig. 10

- The Stirling engine contains a fixed mass of a working gas (usually helium).
- The boiler burns natural gas to heat the working gas in the Stirling engine.
- The piston of the Stirling engine drives an electrical generator.
- The displacer moves the working gas from left to right.
- Cool water returning from the radiators is heated as it passes over the right-hand side of the Stirling engine before flowing back to the radiators again.

(a) (i) State how energy is transferred **to** the working gas.

.....
 [1]

(ii) State how energy is transferred **away from** the working gas.

Give **two** answers.

1
 2 [2]

(iii) The energy entering the working gas in one cycle of the engine is equal to the energy leaving the working gas.

Show that the change in internal energy of the working gas is zero.

Use information in section 6.5.1 of the Formula Booklet to help you.

[2]

(b) A different Stirling engine contains 1.2 g of helium gas at 453 K.

(i) Calculate the pressure of the gas when its volume is 0.006 m^3 .

The specific gas constant for helium is $2.08 \text{ J g}^{-1} \text{ K}^{-1}$.

pressure = Pa [3]

(ii) What is 453 K in $^{\circ}\text{C}$?

..... [1]

END OF QUESTION PAPER

ADDITIONAL ANSWER SPACE

If additional answer space is required, you should use the following lined pages. The question numbers must be clearly shown – for example, 2(b) or 3(a).

A vertical line on the left side of the page is followed by 25 horizontal dotted lines, providing a ruled area for writing answers.

A series of horizontal dotted lines for writing, spanning the width of the page. A solid vertical line is positioned on the left side of the page, serving as a margin.

A series of horizontal dotted lines for writing, spanning the width of the page. A solid vertical line is positioned on the left side of the page, serving as a margin.

A series of horizontal dotted lines for writing, spanning the width of the page.



Oxford Cambridge and RSA

Copyright Information

OCR is committed to seeking permission to reproduce all third-party content that it uses in its assessment materials. OCR has attempted to identify and contact all copyright holders whose work is used in this paper. To avoid the issue of disclosure of answer-related information to candidates, all copyright acknowledgements are reproduced in the OCR Copyright Acknowledgements Booklet. This is produced for each series of examinations and is freely available to download from our public website (www.ocr.org.uk) after the live examination series.

If OCR has unwittingly failed to correctly acknowledge or clear any third-party content in this assessment material, OCR will be happy to correct its mistake at the earliest possible opportunity.

For queries or further information please contact the Copyright Team, OCR (Oxford Cambridge and RSA Examinations), The Triangle Building, Shaftesbury Road, Cambridge CB2 8EA.

OCR is part of Cambridge University Press & Assessment, which is itself a department of the University of Cambridge.

© OCR 2022

C302/2206