

Level 2 Cambridge Technical in Engineering

Unit 1: Fundamentals of mechanical, electrical/electronic

and fluid power engineering

Sample Assessment Material

Date - Morning/Afternoon

Time allowed: 45 minutes

You must have:

- a scientific calculator

First Name						Last Name					
Centre Number						Candidate Number					
Date of Birth											

INSTRUCTIONS

- Use black ink.
- Complete the boxes above with your name, centre number, candidate number and date of birth.
- Answer **all** the questions.
- Write your answer to each question in the space provided.

INFORMATION

- The total mark for this paper is **40**.
- The marks for each question are shown in brackets [].
- This document consists of 18 pages.

Answer **all** the questions.

Put a tick (✓) in the box next to the **one** correct answer for each question.

1 What is the SI unit for electric current?

(a) kelvin

(b) ampere

(c) candela

(d) metre

2 What is a measurement with no errors called?

(a) tolerance

(b) indicated value

(c) true value

(d) accuracy

3 What SI prefix letter can be used to represent the value 10^6 ?

(a) M

(b) G

(c) T

(d) m

4 What is the volume of the cuboid shown below?

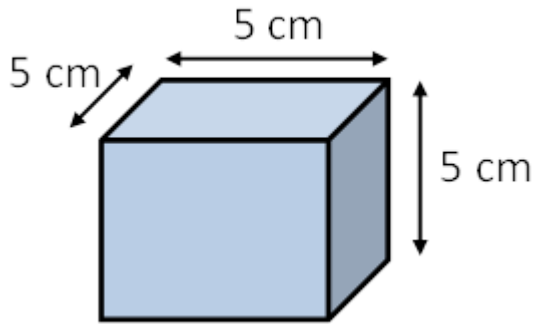

- (a) 5 cm^3
- (b) 15 cm^3
- (c) 25 cm^3
- (d) 125 cm^3

5 Which of the following SI derived units represents force?

- (a) joule
- (b) watt
- (c) newton
- (d) lux

6 What is a ferrous metal?

- (a) A metal that contains copper
- (b) A metal that contains aluminium
- (c) A metal that contains iron
- (d) A metal that contains zinc

7 What type of material is bronze?

- (a) Non-ferrous metal
- (b) Ferrous metal
- (c) Polymer
- (d) Composite

8 What type of material is nylon?

- (a) A ceramic
- (b) A composite
- (c) A polymer
- (d) A smart material

9 What is epoxy resin?

- (a) A smart material
- (b) A thermoplastic
- (c) A thermoset plastic
- (d) A ceramic

10 What type of material is glass?

- (a) A ceramic
- (b) A smart material
- (c) A composite
- (d) A polymer

11 What is an alloy?

- (a) A mixture of two elements, at least one of which is a metal
- (b) A mixture of two thermoplastics, one of which is acrylic
- (c) A mixture of two smart materials
- (d) A mixture of two composite materials

12 Which of the following material can be classified as a 'smart material'?

- (a) Shape-memory plastic
- (b) Glass reinforced plastic (GRP)
- (c) Titanium
- (d) Tungsten carbide

13 What is elasticity?

- (a) The ability of a material to retain a new shape after stretching
- (b) The ability of a material to return to its original shape after stretching
- (c) The ability of a material to break without stretching
- (d) The ability of a material to stretch without ever breaking

14 What is a tough material?

- (a) A material that has resistance to being deformed by compression
- (b) A material that has resistance to being deformed by stretching
- (c) A material that has resistance to wear and abrasion
- (d) A material that has resistance to shock loading and impact

15 Which letter on the force/extension graph below identifies the elastic limit?

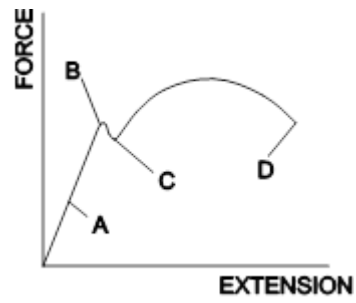

(a) A

(b) B

(c) C

(d) D

16 What is strain?

(a) The response of a system to an applied stress

(b) The response of a system to temperature change

(c) The response of a system to a breaking point

(d) The response of a system to plastic deformation

17 The image below shows a mechanical hacksaw cutting a steel bar.

What type of motion does the hacksaw use on its cutting stroke?

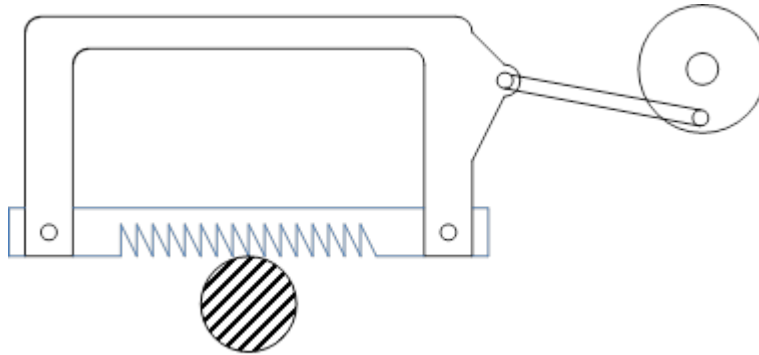

- (a) Rotary
- (b) Reciprocating
- (c) Linear
- (d) Oscillating

18 The diagram below shows a piece of metal held in the jaws of a bench vice. What forces are acting upon the piece of metal?

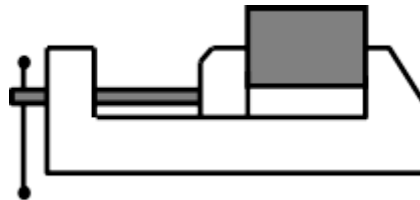

- (a) Compressive forces
- (b) Tensional forces
- (c) Torsional forces
- (d) Bending forces

19 Which of the following diagrams shows a class 3 lever arrangement?

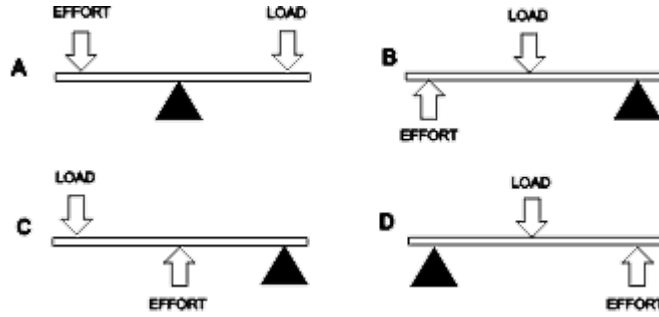

- (a) A
- (b) B
- (c) C
- (d) D

20 What is the mechanical advantage (MA) for a lever when the Load is 300N and Effort is 10N?

- (a) 0.3
- (b) 30
- (c) 300
- (d) 3000

21 Which letter on the parallel linkage system arrangement shown below identifies the position of the fixed pivot?

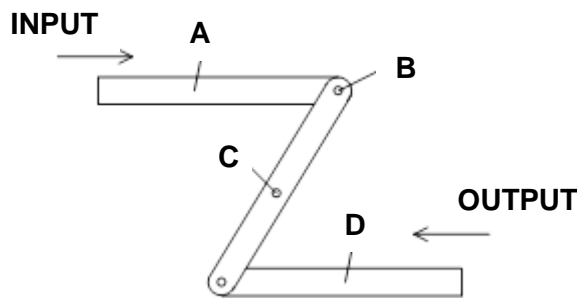

- (a) A
- (b) B
- (c) C
- (d) D

22 What type of pulley system arrangement is shown in the diagram below?

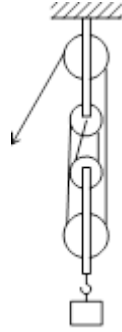

- (a) 1:1
- (b) 2:1
- (c) 3:1
- (d) 4:1

23 What is the velocity ratio (VR) for a simple pulley system when the driver pulley has a diameter of 5 cm and the driven pulley has a diameter of 50 cm?

- (a) 0.1
- (b) 10
- (c) 45
- (d) 250

24 What type of gear system is shown in the image below?



- (a) Helical gears
- (b) Worm gears
- (c) Spur gears
- (d) Bevel gears

25 What is the velocity ratio (VR) for a gear system where the number of teeth on the driver gear is 80 and the number of teeth on the driven gear is 40?

- (a) 0.5
 (b) 2
 (c) 40
 (d) 3200

26 What is an electric current that flows in one direction only called?

- (a) Alternating Current
 (b) Direct Current
 (c) Oscillating Current
 (d) Straight Current

27 How are resistors **R2** and **R3** connected in the circuit below?

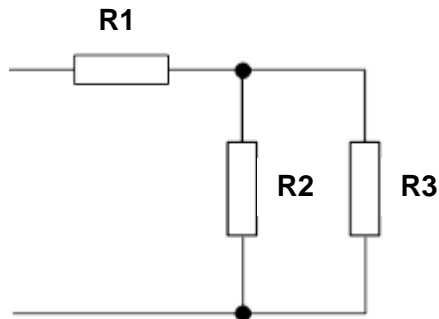

- (a) Star
 (b) Delta
 (c) Parallel
 (d) Series

28 What is the line labelled A in the system block diagram below?

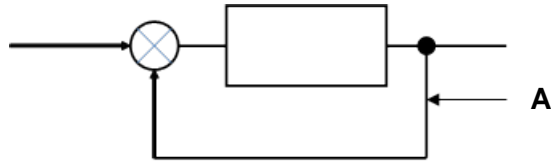

- (a) Feedback
 (b) Input
 (c) Output
 (d) Process

29 Using Ohms Law, what is the value of current (I) flowing in the series circuit below?

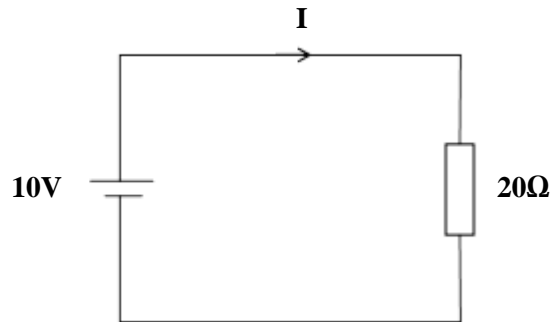

- (a) 0.5 A
 (b) 2 A
 (c) 10 A
 (d) 200 A

30 What part of the DC motor is labelled A in the image below?

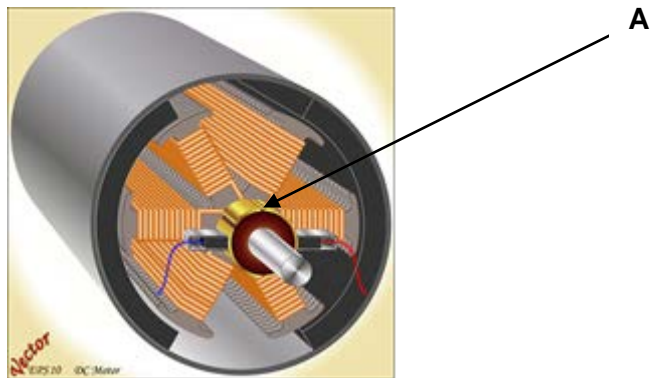

- (a) Commutator
- (b) Stator
- (c) Armature
- (d) Bearing

31 How are the AC motor windings connected below?

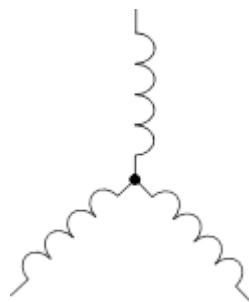

- (a) Shunt
- (b) Series
- (c) Delta
- (d) Star

32 What type of logic gate symbol is shown below?

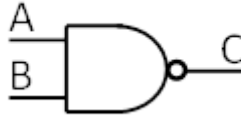

- (a) AND
- (b) OR
- (c) NAND
- (d) NOR

33 What is the total resistance of the circuit shown below?

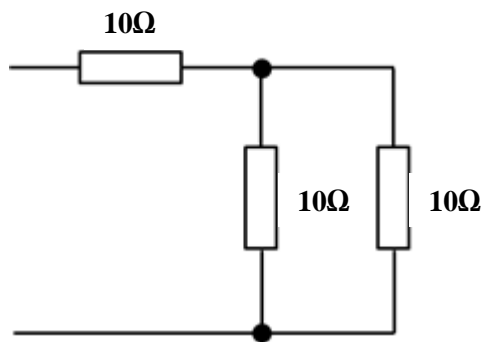

- (a) 10 Ω
- (b) 15 Ω
- (c) 20 Ω
- (d) 30 Ω

34 What type of process device is shown below?

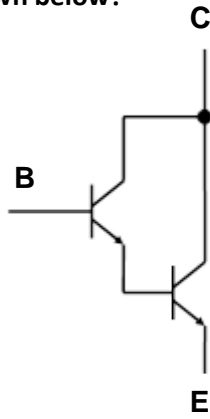

- (a) Diode
- (b) Darlington Pair
- (c) Transistor
- (d) Microprocessor

35 What fluid power symbol is shown below?

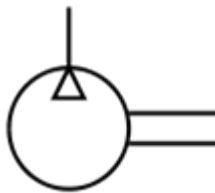

- (a) Shuttle valve
- (b) Receiver
- (c) Compressor
- (d) Linear single acting cylinder

36 What type of fluid power valve symbol is shown below?

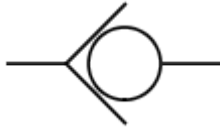

- (a) Directional
- (b) Reducing
- (c) Regulating
- (d) Non-return

37 What fluid power valve activation type is shown below?

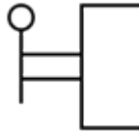

- (a) Push
- (b) Lever
- (c) Roller tip
- (d) Solenoid

38 Which of the following fluid power symbols is a 5/3 valve?

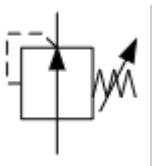
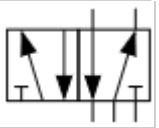
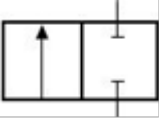
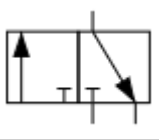
- (a) 
- (b) 
- (c) 
- (d) 

39 What is the missing term in the formula below?

$$Pressure = \frac{Force}{?}$$

- (a) Flow
- (b) Volume
- (c) Time
- (d) Area

40 If the flow rate of fluid in a pipe is 20 cm³ per minute how long does it take for 200 cm³ of fluid to flow?

- (a) 1 minute
- (b) 10 minutes
- (c) 180 minutes
- (d) 4000 minutes

END OF QUESTION PAPER

PLEASE DO NOT WRITE ON THIS PAGE

PLEASE DO NOT WRITE ON THIS PAGE

OCR

Oxford Cambridge and RSA

Copyright Information:

Permission to reproduce items where third-party owned material protected by copyright is included has been sought and cleared where possible. Every reasonable effort has been made by the publisher (OCR) to trace copyright holders, but if any items requiring clearance have unwittingly been included, the publisher will be pleased to make amends at the earliest possible opportunity.

OCR is part of the Cambridge Assessment Group. Cambridge Assessment is the brand name of University of Cambridge Local Examinations Syndicate (UCLES), which is itself a department of the University of Cambridge

OCR

Oxford Cambridge and RSA

SPECIMEN

Sample Assessment Material

LEVEL 2 CAMBRIDGE TECHNICALS IN ENGINEERING

Unit 1: Fundamentals of mechanical, electrical/electronic and fluid power engineering

MARK SCHEME

Duration: 45 minutes

MAXIMUM MARK 40

SPECIMEN

Version: 1 Date: September 2016

This document consists of 2 pages

Mark Scheme**SPECIMEN**

Question	Answer
1	B
2	C
3	A
4	D
5	C
6	C
7	A
8	C
9	C
10	A
11	A
12	A
13	B
14	D
15	B
16	A
17	C
18	A
19	C
20	B
21	C

Question	Answer
22	D
23	B
24	D
25	A
26	B
27	C
28	A
29	A
30	A
31	D
32	C
33	B
34	B
35	C
36	D
37	B
38	B
39	D
40	B